

6

5

4

3

2

1

D

C

B

A

D

C

B

A

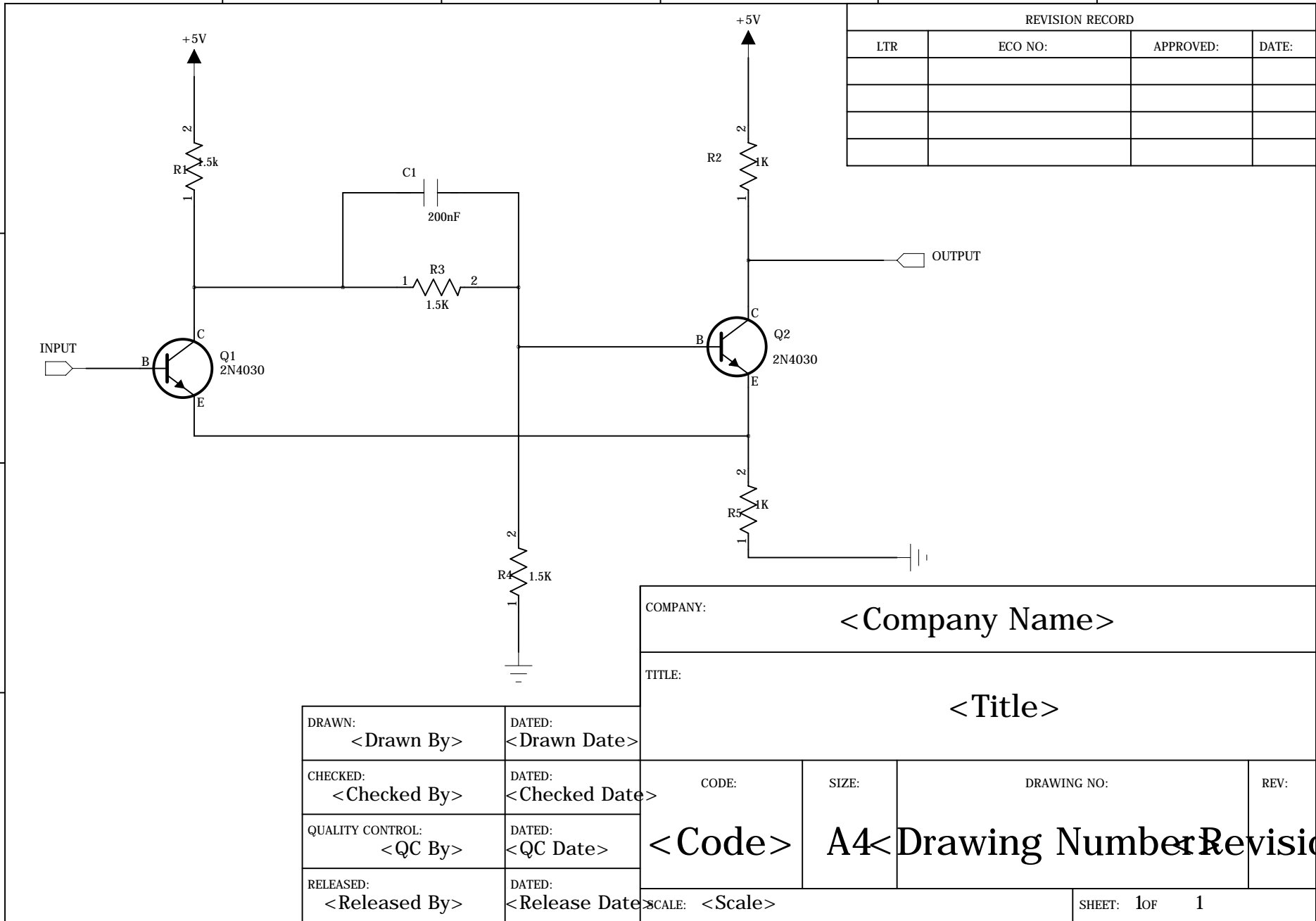

REVISION RECORD			
LTR	ECO NO:	APPROVED:	DATE:

COMPANY:				<Company Name>							
TITLE:				<Title>							
DRAWN:		DATED:		CODE:		SIZE:		DRAWING NO:		REV:	
<Drawn By>		<Drawn Date>		<Code>		A4		<Drawing Number>		<Revision>	
CHECKED:		DATED:		SCALE: <Scale>							
<Checked By>		<Checked Date>									
QUALITY CONTROL:		DATED:		SHEET: 1 OF 1							
<QC By>		<QC Date>									
RELEASED:		DATED:		SHEET: 1 OF 1							
<Released By>		<Release Date>									